



RAASM MOBILE WASTE OIL DRAINER

Gravity and air operated suction drainers. Ideal for quick engine oil change of any motor vehicle. Waste oil can be collected by gravity, using the bowl mounted on the adjustable support, or by suction through the supplied probes. After depressurisation the drainer works independently without requiring continuous connection to the compressed air system.

FEATURES & BENEFITS:

- Equipped with level gauge, collection bowl, anti splash screen filter and removable tool tray
- Anti-splash screen filter
- Removable Tool tray
- Drain bowl capacity of 15L
- Level Indicator with scale in litres and gallons
- A clean and safety conscious workshop managers dream to improve the waste oil evacuation efficiency in their operation
- Max. Working Height: 1780-1900mm
- Min. Working Height: 1270-1400mm

SPECIFICATIONS:

Bowl capacity	15 L
Discharging/Suction hose	Draining 2 m
Max pressure for discharging	0.5 bar
Dimensions	120x80x85



AF-RA-42065

AF-RA-42085

AF-RA-42090

PART NO.		TANK CAPACITY	MAX DRAINING CAPACITY	WEIGHT
AF-RA-42065	RAASM 65L Mobile Waste Oil Drainer - (2) Two Boxes Included	65 L	52 L	33 Kg
AF-RA-42085	RAASM 80L Mobile Waste Oil Drainer - (1) One Box Only	80 L	62 L	33 Kg
AF-RA-42090	RAASM 90L Mobile Waste Oil Drainer - (2) Two Boxes Included	90 L	75 L	34 kg



RAASM MOBILE WASTE OIL DRAINER

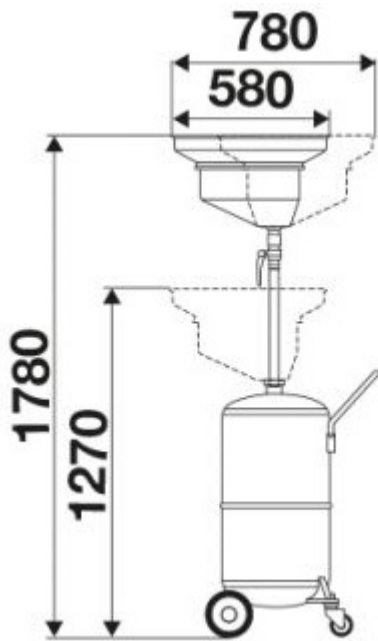

AF-RA-42065

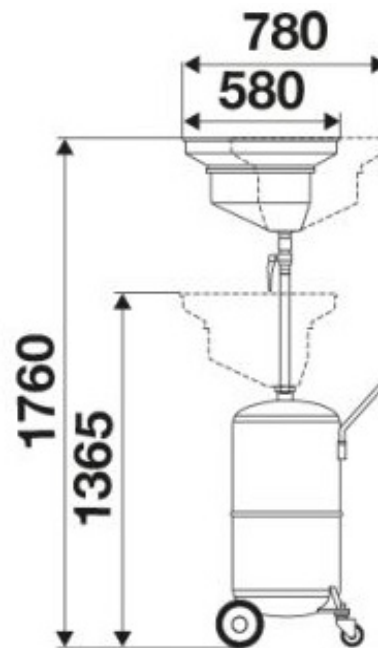

AF-RA-42085

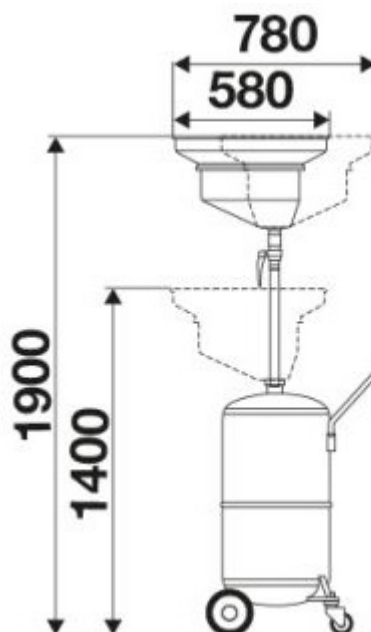

AF-RA-42090